

1 FIRST FLOOR PLAN

A1.00 SCALE: 1/8" = 1'-0"



10/05/2018

RLC Architects
 14 SEE ANN STREET, BOCA RATON, FL 33432
 TEL 561 393 0555 FAX 561 393 0077
 WWW.RLCARCHITECTS.COM
 STATE OF FLORIDA REGISTERED ARCHITECTS NO. AA38001060
 THE DRAWINGS AND ALL THE DETAILS, ARRANGEMENTS, DESIGNS AND PLANS
 HEREON ARE THE PROPERTY OF RLC ARCHITECTS, P.A. AND NO PART THEREOF
 SHALL BE REPRODUCED OR TRANSMITTED IN ANY FORM OR BY ANY MEANS
 WITHOUT THE WRITTEN PERMISSION OF RLC ARCHITECTS, P.A.

Digitally signed by Juan Caycedo
 DN: cn=Juan Caycedo, o=RLC Architects, ou=RLC Architects, email=jcaycedo@rlcarchitects.com
 Reason: I agree to the terms defined by the statement of my signature on this document
 Date: 2018.10.05 14:58:24 -0400

Lyons Community Center
 7650 Lyons Road
 Coconut Creek, Florida

NO.	REVISIONS
1	
2	
3	
4	
5	
6	
7	
8	
9	
10	
11	
12	
13	
14	
15	
16	

LEVEL ONE FLOOR PLAN
 Scale 1/8" = 1'-0"
 Project No. 17015.00
 Date 05/24/2018

Principal: JCC
 Project Director: XXX
 Project Manager: XXX
 Drafted by: APD
 Checked by:

Sheet No.
A1.00

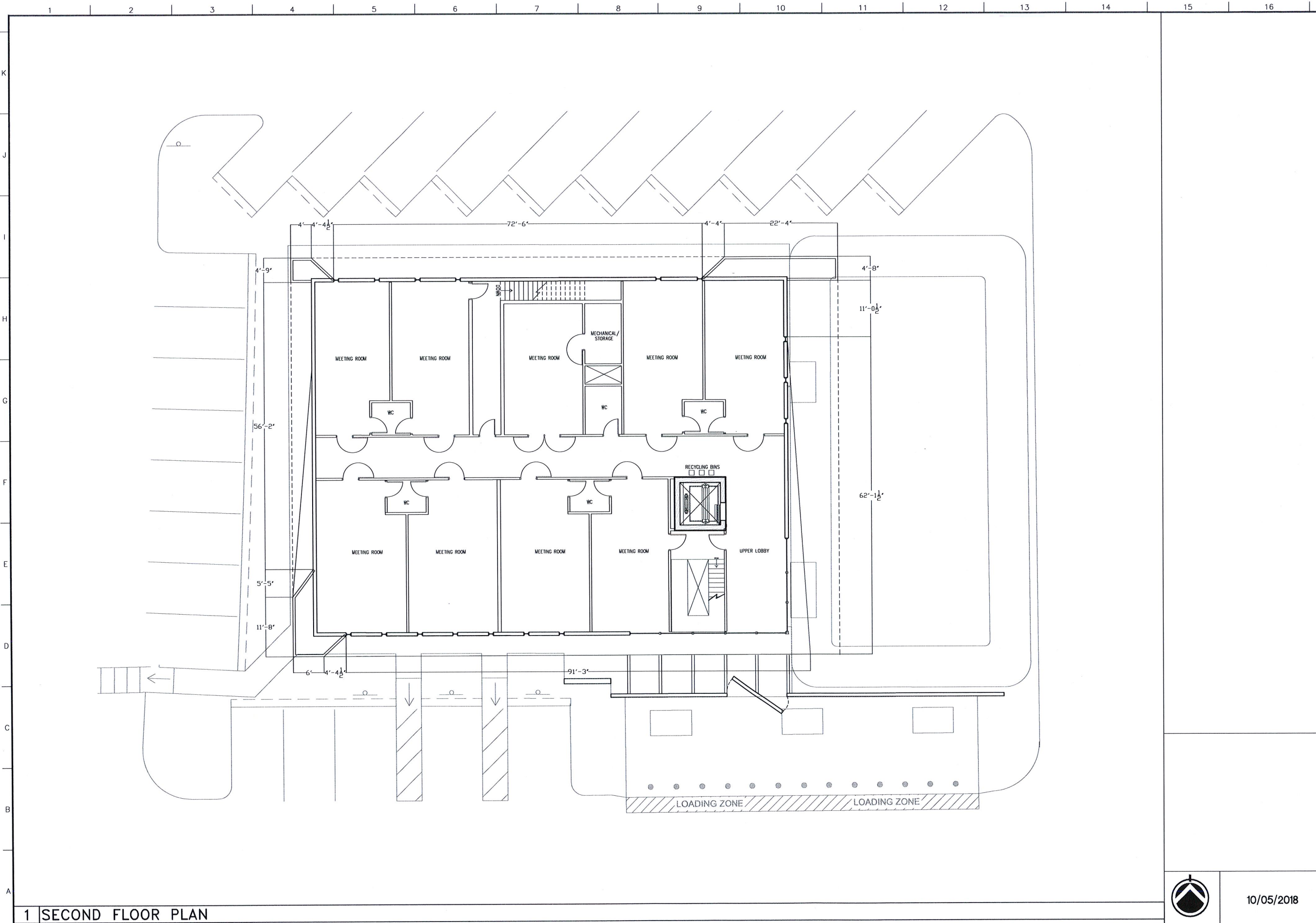

1 SECOND FLOOR PLAN

A1.10 SCALE: 1/8" = 1'-0"



10/05/2018

RLC Architects
 1401 W. Highway 1, Suite 100, Ft. Myers, FL 33901
 Tel: 813-335-8555 Fax: 813-335-0007
 Web: www.rlcarchitects.com

COPYRIGHT © RLC ARCHITECTS, P.A. ARCHITECTS No. AAS000000
 ALL RIGHTS RESERVED. THIS DRAWING IS THE PROPERTY OF RLC ARCHITECTS, P.A. AND IS TO BE USED ONLY FOR THE PROJECT AND SITE SPECIFICALLY IDENTIFIED HEREON. NO PART OF THIS DRAWING SHALL BE REPRODUCED, COPIED, OR TRANSMITTED IN ANY FORM OR BY ANY MEANS, ELECTRONIC OR MECHANICAL, WITHOUT THE WRITTEN PERMISSION OF RLC ARCHITECTS, P.A.

Digitally signed by Juan Caycedo
 DN: cn=Juan Caycedo, o=RLC Architects, ou=RLC Architects, email=jcaycedo@rlcarchitects.com
 Reason: I am the issuer of this signature
 Date: 2018.05.24 15:05:53-0500

Lyons Community Center
 7650 Lyons Road
 Coconut Creek, Florida

NO.	REVISIONS
1	
2	
3	
4	
5	
6	
7	
8	
9	

LEVEL TWO
 FLOOR PLAN

Scale 1/8" = 1'-0"
 Project No. 17015.00
 Date 05/24/2018

Principal: JCC
 Project Director: XXX
 Project Manager: XXX
 Drafted by: APD
 Checked by:

Sheet No.
A110

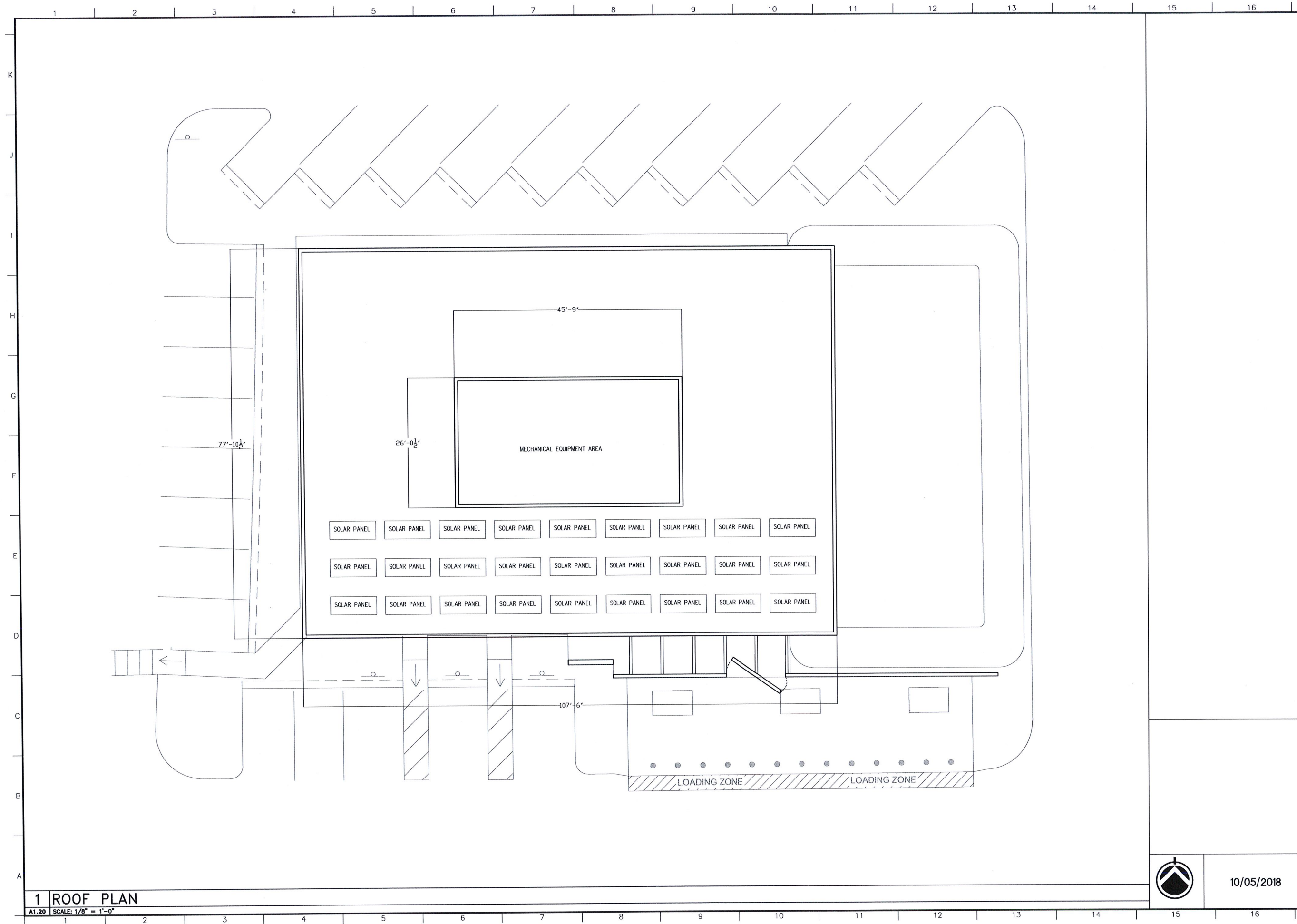

1 ROOF PLAN

A1.20 SCALE: 1/8" = 1'-0"

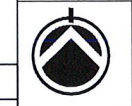

10/05/2018

RLC Architects
 1500 Lyons Road
 Coconut Creek, FL 33433
 Tel: 954.333.8555 Fax: 954.333.0307
 Web: www.rlcarchitects.com

COPYRIGHT RLC ARCHITECTS, P.A. ARCHITECTS No. A43800160
 STATE OF FLORIDA REGISTERED ARCHITECTS No. 145000160
 THIS DOCUMENT IS THE PROPERTY OF RLC ARCHITECTS, P.A. AND IS TO BE USED ONLY FOR THE PROJECT AND SITE SPECIFICALLY INDICATED HEREON. NO REPRODUCTION OR TRANSMISSION OF ANY KIND IS PERMITTED WITHOUT THE WRITTEN PERMISSION OF RLC ARCHITECTS, P.A.

Digitally signed by Juan Caycedo
 DN: cn=Juan Caycedo, o=RLC Architects, ou=RLC Architects, email=jcaycedo@rlcarchitects.com
 Reason: I agree to the placement of my signature in this document.
 Date: 2018.10.05 15:00:06-0500
 15.00.06.0107

Lyons Community Center
 7650 Lyons Road
 Coconut Creek, Florida

NO.	REVISIONS
1	
2	
3	
4	
5	
6	
7	
8	
9	

ROOF PLAN

Scale 1/8" = 1'-0"
 Project No. 17015.00
 Date 05/24/2018

Principal: JCC
 Project Director: XXX
 Project Manager: XXX
 Drafted by: APD
 Checked by:

Sheet No.
A1.20



1 SOUTH-WEST PERSPECTIVE RENDERING

A3.00 SCALE: N.T.S.



2 SOUTH-EAST PERSPECTIVE RENDERING

A3.00 SCALE: N.T.S.

RLC

14 SE 4th Street, Boca Raton, FL 33432
 Tel: 561 369 8855 Fax: 561 369 0077
 www.rlcarchitects.com
 STATE OF FLORIDA REGISTERED ARCHITECTS No. A23007893
 THE DRAFTING AND ALL THE DEAS, ARRANGEMENTS, EDITIONS AND PLANS
 HEREON ARE THE PROPERTY OF RLC ARCHITECTS, P.A. AND NOT PART THEREOF.
 NO PART OF THIS DOCUMENT IS TO BE REPRODUCED OR TRANSMITTED IN ANY
 FORM OR BY ANY MEANS, ELECTRONIC OR MECHANICAL, INCLUDING PHOTOCOPYING,
 RECORDING, OR BY ANY INFORMATION STORAGE AND RETRIEVAL SYSTEM, WITHOUT THE
 WRITTEN PERMISSION OF RLC ARCHITECTS, P.A.

Digitally signed by Juan Caycedo
 DN: cn=Juan Caycedo, o=RLC Architects, ou=RLC Architects, email=Juan.Caycedo@rlcarchitects.com
 Reason: I agree to the terms defined by the placement of my signature on this document.
 Date: 2018.10.08 18:27:48-0400

Lyons Community Center
7650 Lyons Road
Coconut Creek, Florida

REVISIONS
1
2
3
4
5
6
7
8
9
10
11
12
13
14
15
16

RENDERINGS

Scale: N.T.S.
 Project No. 17015.00
 Date 05/24/2018

Principal: JCC
 Project Director: XXX
 Project Manager: XXX
 Drafted by: APD
 Checked by:

Sheet No.
A3.00

10/05/2018

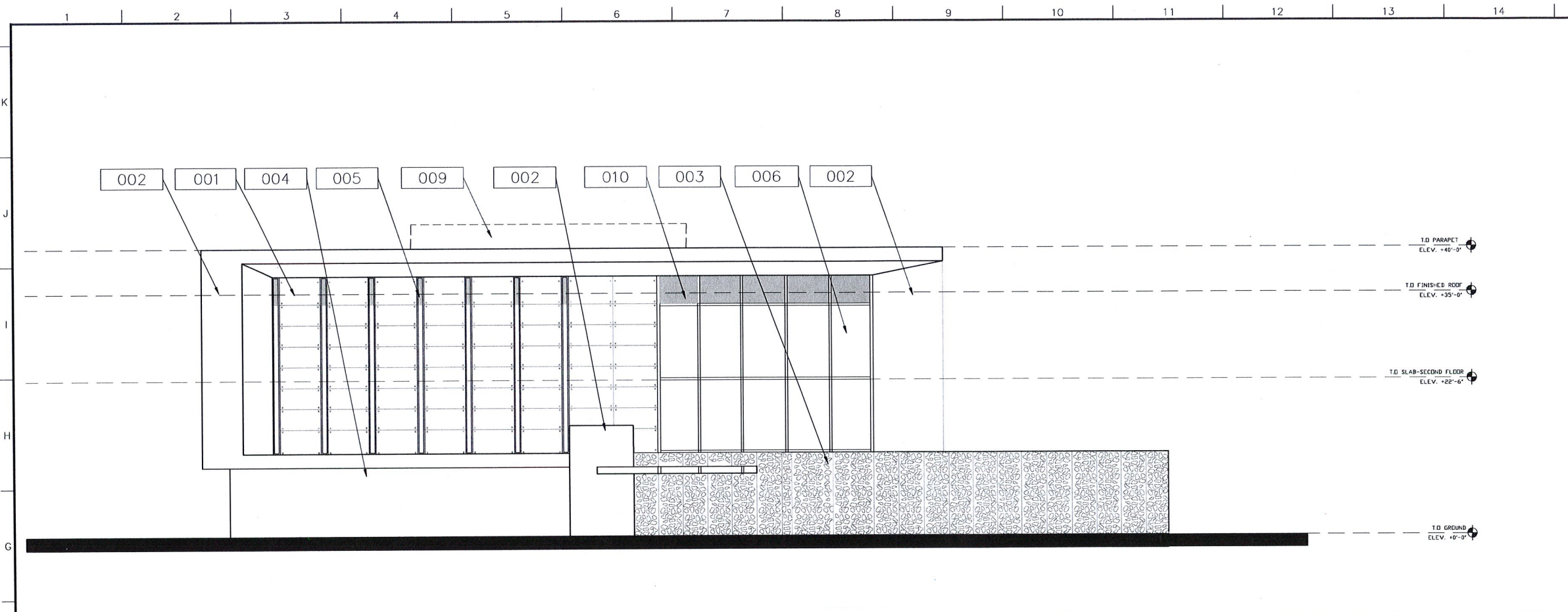

1 SOUTH ELEVATION

A3.10 SCALE: 1/8" = 1'-0"

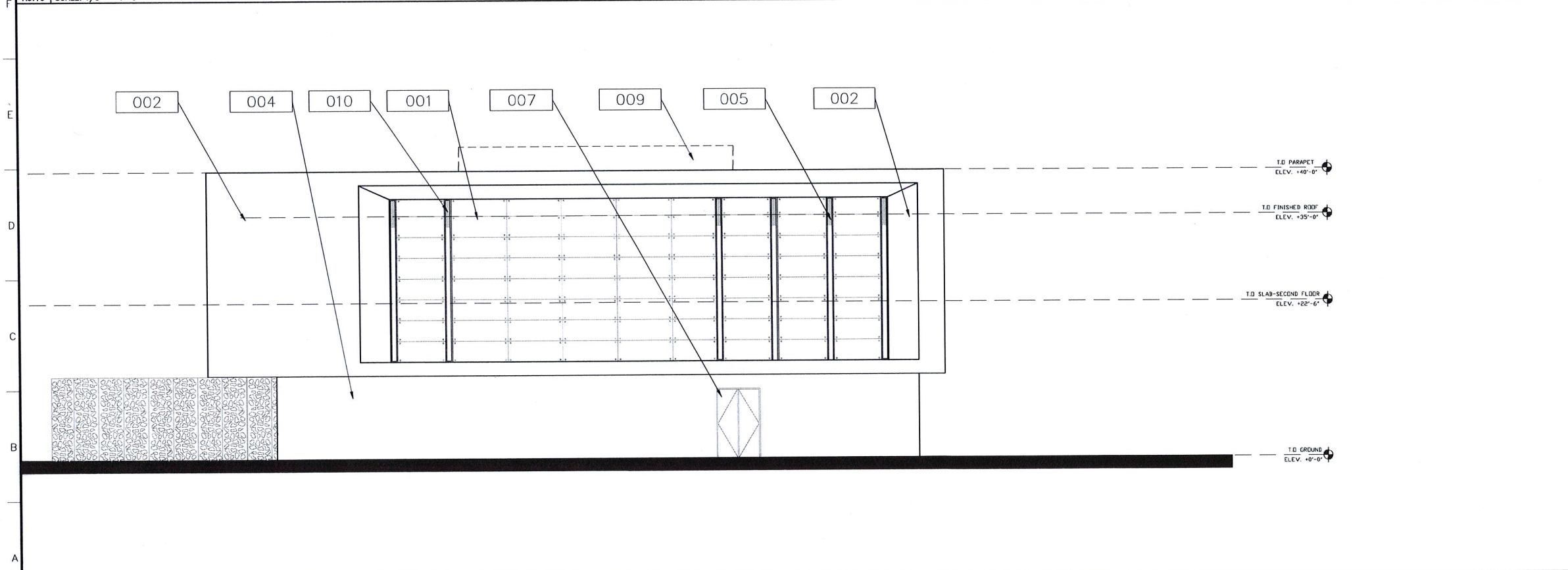

2 NORTH ELEVATION

A3.10 SCALE: 1/8" = 1'-0"

MATERIAL TABLE

- 001 - CONCRETE PANEL CLADDING WITH STAINLESS STEEL SUPPORTS
- 002 - SMOOTH STUCCO FINISH
- 003 - DECORATIVE METAL SCREEN
- 004 - VEGETATION WALL OR WOOD PANEL CLADDING
- 005 - WINDOW WITH ALUMINUM FRAME
- 006 - STORE FRONT SYSTEM ALUMINUM FRAME
- 007 - METAL DOOR
- 008 - STOREFRONT DOOR ALUMINUM FRAME
- 009 - NONE STRUCTURAL METAL MECHANICAL SCREEN
- 010 - SPANDREL GLASS

NOTES

- 1.00 - METAL DECORATIVE SCREEN DESIGN SHOWN IS A PLACEHOLDER, NOT FINIAL

RLC Architects
 ARCHITECTS, P.A.
 7650 LYONS ROAD
 COCONUT CREEK, FL 33093
 TEL: 561.392.0655 FAX: 561.392.0027
 WWW.RLCARCHITECTS.COM

COPYRIGHT RLC ARCHITECTS, P.A. PROJECT NO. A3.10/019.0
 STATE OF FLORIDA REGISTERED ARCHITECTS LICENSE NO. 143600000
 THIS DOCUMENT IS THE PROPERTY OF RLC ARCHITECTS, P.A. AND IS TO BE USED ONLY FOR THE PROJECT AND SITE INDICATED THEREON. NO REPRODUCTION OR TRANSMISSION OF THIS DOCUMENT IS PERMITTED WITHOUT THE WRITTEN PERMISSION OF RLC ARCHITECTS, P.A. ANY REPRODUCTION OR TRANSMISSION OF THIS DOCUMENT SHALL BE AT THE USER'S SOLE RISK AND WITHOUT LIABILITY TO RLC ARCHITECTS, P.A.

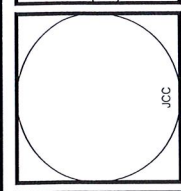

Lyons Community Center
 7650 Lyons Road
 Coconut Creek, Florida

REVISIONS

1					
2					
3					
4					
5					
6					
7					
8					
9					
10					
11					
12					
13					
14					
15					
16					

NORTH-SOUTH ELEVATIONS

Scale 1/8" = 1'-0"
 Project No. 17015.00
 Date 01/29/2019

Principal: JCC
 Project Director: XXX
 Project Manager: XXX
 Drafted by: APD
 Checked by:

Sheet No.
A3.10

01/29/2019

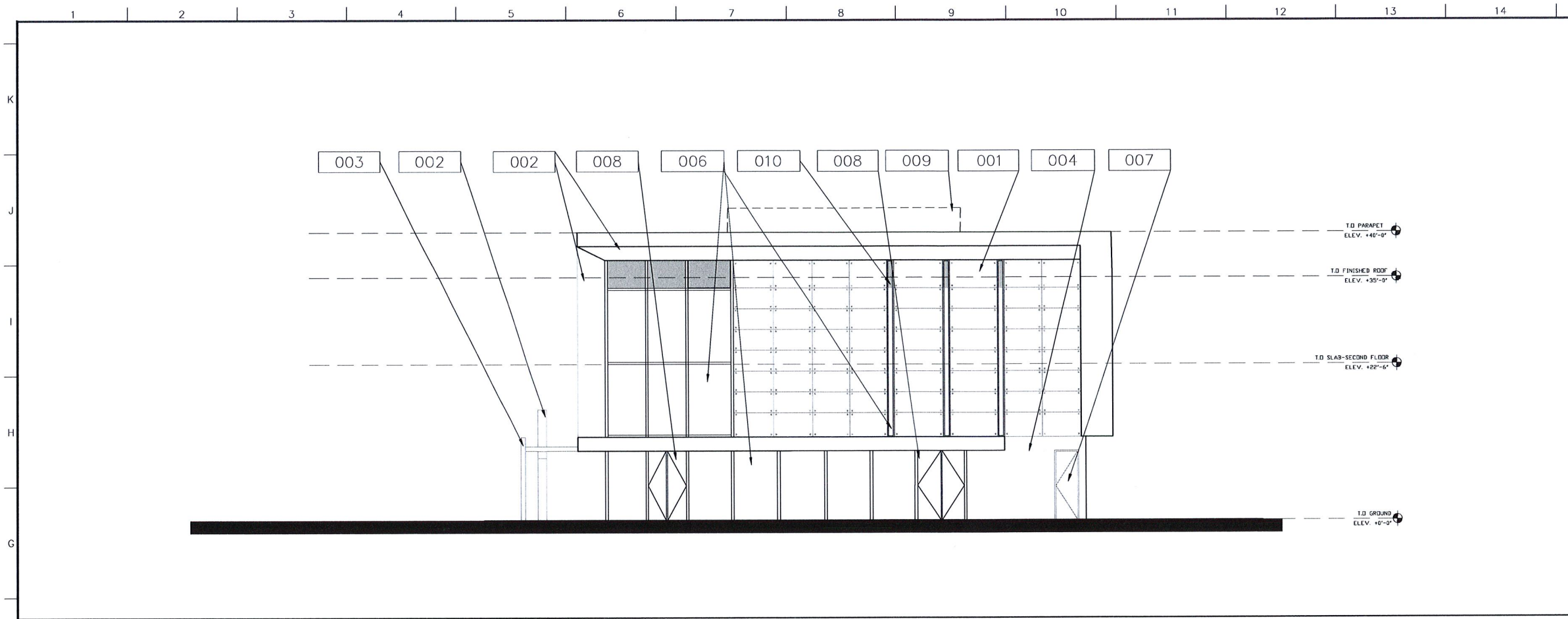

1 EAST ELEVATION
 A3.20 SCALE: 1/8" = 1'-0"

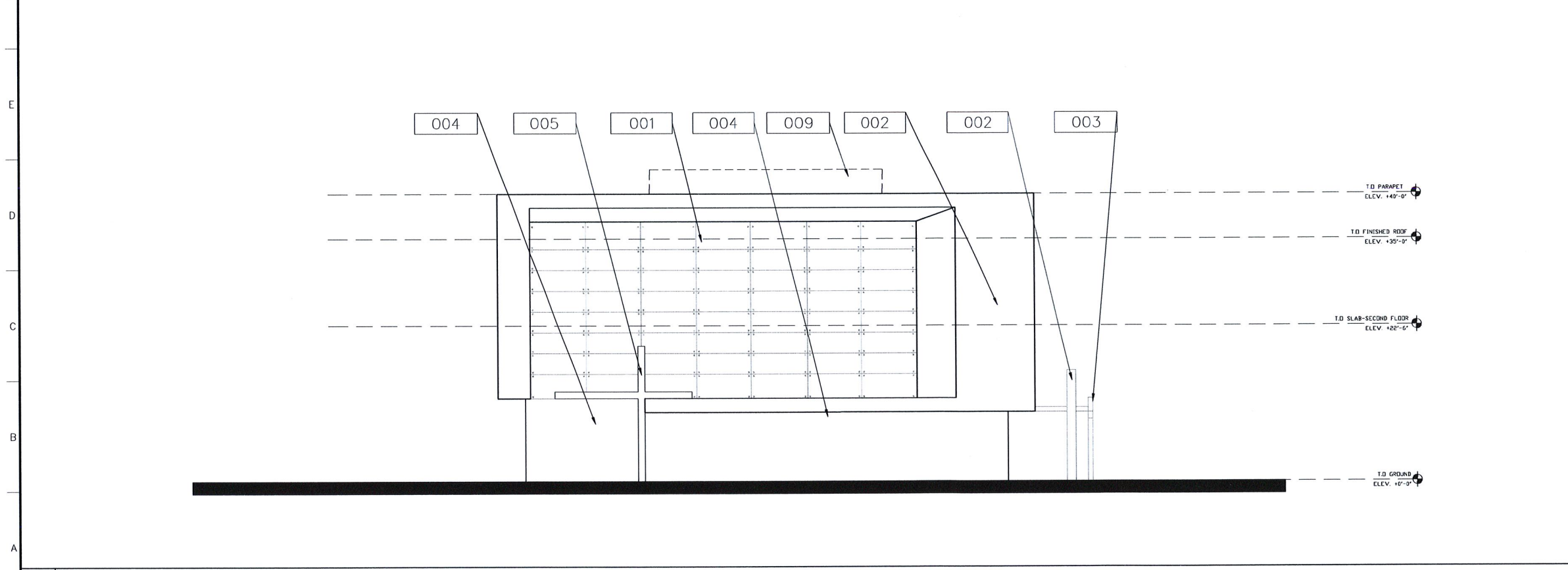

2 WEST ELEVATION
 A3.20 SCALE: 1/8" = 1'-0"

MATERIAL TABLE	
001	CONCRETE PANEL CLADDING WITH STAINLESS STEEL SUPPORTS
002	SMOOTH STUCCO FINISH
003	DECORATIVE METAL SCREEN
004	VEGETATION WALL OR WOOD PANEL CLADDING
005	WINDOW WITH ALUMINUM FRAME
006	STORE FRONT SYSTEM ALUMINUM FRAME
007	METAL DOOR
008	STOREFRONT DOOR ALUMINUM FRAME
009	NONE STRUCTURAL METAL MECHANICAL SCREEN
010	SPANDREL GLASS

NOTES

1.00 - METAL DECORATIVE SCREEN DESIGN SHOWN IS A PLACEHOLDER, NOT FINIAL

RLC Architects
 14 SE 8th Street, Suite 200, Ft. Lauderdale, FL 33304
 Copyright RLC Architects, P.A.
 STATE OF FLORIDA REGISTERED ARCHITECTS No. A48080D
 ALL RIGHTS RESERVED. NO PART OF THIS DOCUMENT IS TO BE REPRODUCED OR TRANSMITTED IN ANY FORM OR BY ANY MEANS, ELECTRONIC OR MECHANICAL, INCLUDING PHOTOCOPYING, RECORDING, OR BY ANY INFORMATION STORAGE AND RETRIEVAL SYSTEM, WITHOUT THE WRITTEN PERMISSION OF RLC ARCHITECTS, P.A.

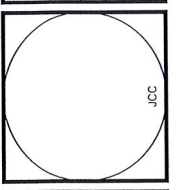

Lyons Community Center
 7650 Lyons Road
 Coconut Creek, Florida

REVISIONS

EAST-WEST ELEVATIONS

Scale 1/8" = 1'-0"
 Project No. 17015.00
 Date 01/29/2019

Principal: JCC
 Project Director: XXX
 Project Manager: XXX
 Drafted by: APD
 Checked by:

Sheet No.
A3.20

01/29/2019

J:\109511\5.9 Drawings\59civil\lyons\109511-SP-A-1.dwg Modified: 2/4/2019 By: cpmce Plotted By: christopher_pence

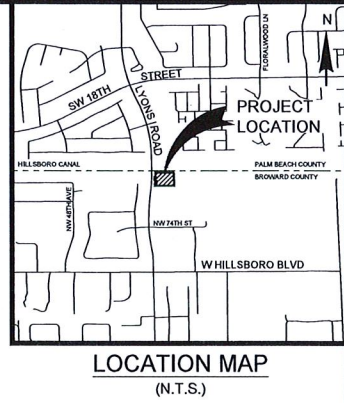
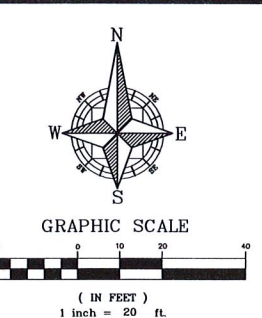
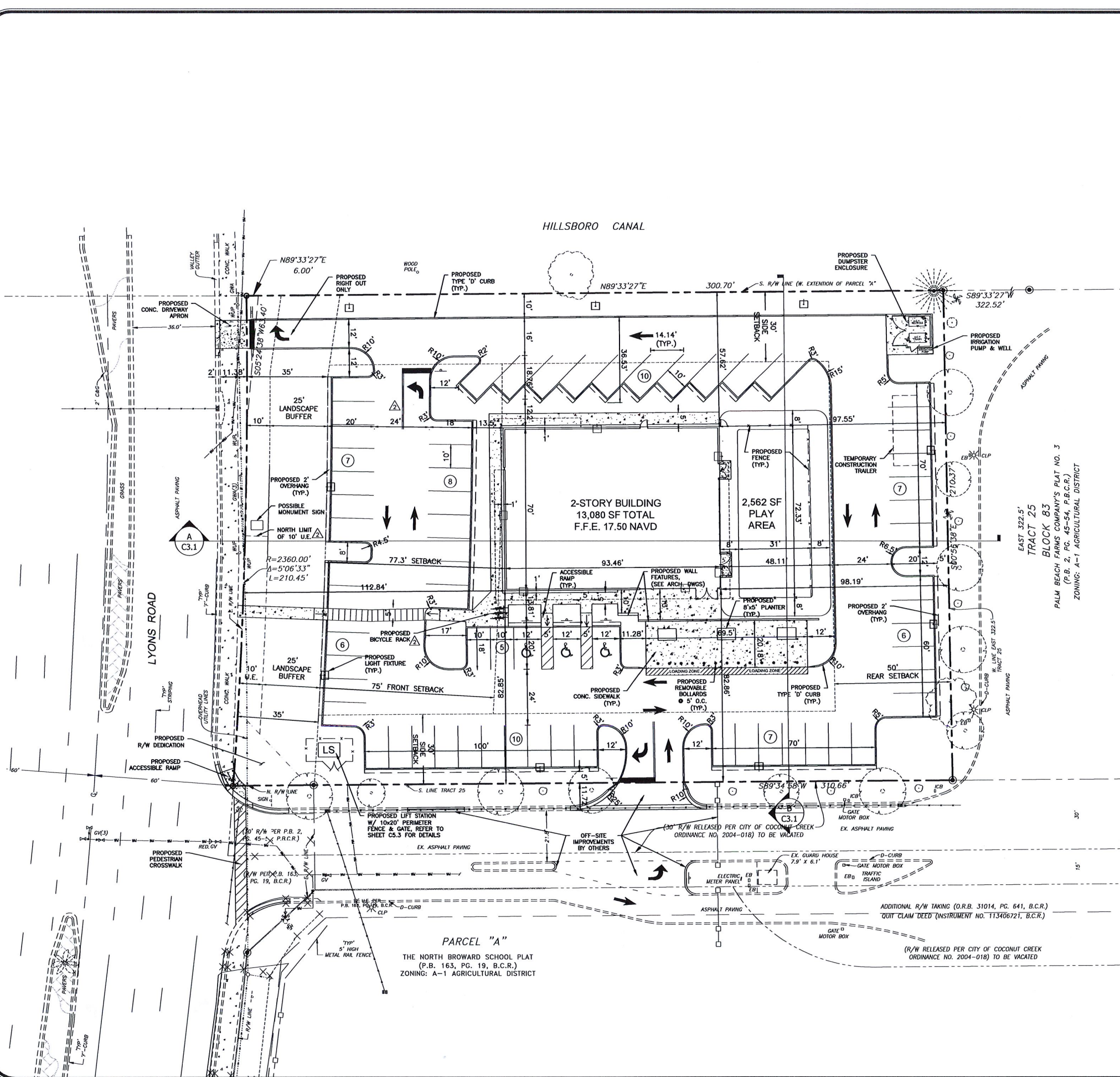

SITE DATA:

PARCEL ID#	4742320100
TOTAL ACREAGE	1.468 ACRES (63,952 SF)
EXISTING IMPERVIOUS AREA:	
• BUILDINGS	0.113 ACRES (4,913 SF) 7.68%
• ASPHALT/PAVERS/CONCRETE	0.071 ACRES (3,074 SF) 4.81%
EXISTING PERVIOUS AREA:	
• OPEN SPACE	1.284 ACRES (55,965 SF) 87.51%
PROPOSED IMPERVIOUS AREA:	
• BUILDING FIRST FLOOR	0.150 ACRES (6,540 SF)
• BUILDING SECOND FLOOR	0.150 ACRES (6,540 SF) 10.23%
• BUILDING FOOTPRINT	0.086 ACRES (3,741 SF) 5.85%
• SIDEWALK/CONCRETE	
PROPOSED PERVIOUS AREA:	
• PERVIOUS CONCRETE PAVEMENT (5% MIN. PERMEABILITY)	0.679 ACRES (29,581 SF) 46.26%
• PLAY AREA	0.059 ACRES (2,562 SF) 4.01%
• GREEN SPACE	0.494 ACRES (21,526 SF) 33.65%
PROPOSED OPEN SPACE:	
• REQUIRED OPEN SPACE	0.659 ACRES (28,700 SF) 44.89%
• PROVIDED OPEN SPACE	0.638 ACRES (27,800 SF) 43.47%
EXISTING LAND USE DESIGNATION	E1 (RESIDENTIAL ESTATE - 1 DU/AC)
PROPOSED LAND USE DESIGNATION	E1 (RESIDENTIAL ESTATE - 1 DU/AC)
EXISTING ZONING DESIGNATION	A-1 (AGRICULTURAL DISTRICT)
PROPOSED ZONING DESIGNATION	A-1 (AGRICULTURAL DISTRICT)
MAXIMUM BUILDING HEIGHT	35'-0"
FINISHED ROOF HEIGHT	35'-0"
TOP OF PARAPET ELEVATION	40'-0"

PARKING REQUIREMENTS FOR A-1 ZONING PER §13-402:

• CHURCH ATTENDANCE:	198
• REQUIRED PARKING:	
• 1 SPACE FOR EACH THREE (3) SEATS =	66 SPACES
• PROVIDED PARKING:	66 SPACES
• ACCESSIBLE PARKING SPACES:	
• REQUIRED FOR 51-75 SPACES =	3 SPACES
• ACCESSIBLE SPACES PROVIDED:	3 SPACES

OUTSIDE PLAY AREA REQUIREMENT:

• 45 SF OF PLAY AREA FOR EACH CHILD:	
• 50 CHILDREN AT ANY ONE TIME) x 45 SF =	2,250 SF REQUIRED
• PLAY AREA PROVIDED:	2,562 SF

SCHEDULE OF USE:
 WEEKDAY SCHEDULE FOR BIBLE STUDY
 7PM - 11PM
 WEEKEND CHURCH SERVICES
 8AM - 2PM (SUNDAY ONLY)

<p>IBI GROUP (FLORIDA) INC 1100 Park Central Boulevard South - Suite 3500 Pompano Beach FL 33064 USA tel 954 974 2200 fax 954 973 2686 ibigroup.com</p>	<p>LANDSCAPE LC 88000270 ENGINEERS CERT. OF AUTH. #8986</p>
<p>LYONS COMMUNITY CENTER 7650 LYONS, COCONUT CREEK, FL.</p>	<p>SITE PLAN</p>
<p>NOT FOR CONSTRUCTION</p>	
<p>DRAWN: CMP DESIGNED: CMP CHECKED: PFR DATE: 3/7/2018</p>	<p>SCALE: 1" = 20' PROJECT: 109511 SHEET: C3.0</p>

48 HOURS BEFORE DIGGING
 CALL TOLL FREE
 811 or 1-800-432-4770
 SUNSHINE STATE ONE CALL CENTER

DISCLAIMER
 This drawing, as an instrument of service, is the property of the Engineer and may not be reproduced without their permission and unless the reproduction carries their name. All design and other information shown on this drawing are for the use on the specified project only and shall not be used otherwise without written permission of the Engineer. Written dimensions shall have precedence over scaled dimensions. Contractors shall verify and be responsible for all dimensions and conditions on the job and the Engineer shall be informed of any variations from the dimensions and conditions shown on the drawing. Shop drawings shall be submitted to the Engineer for approval before proceeding with fabrication.

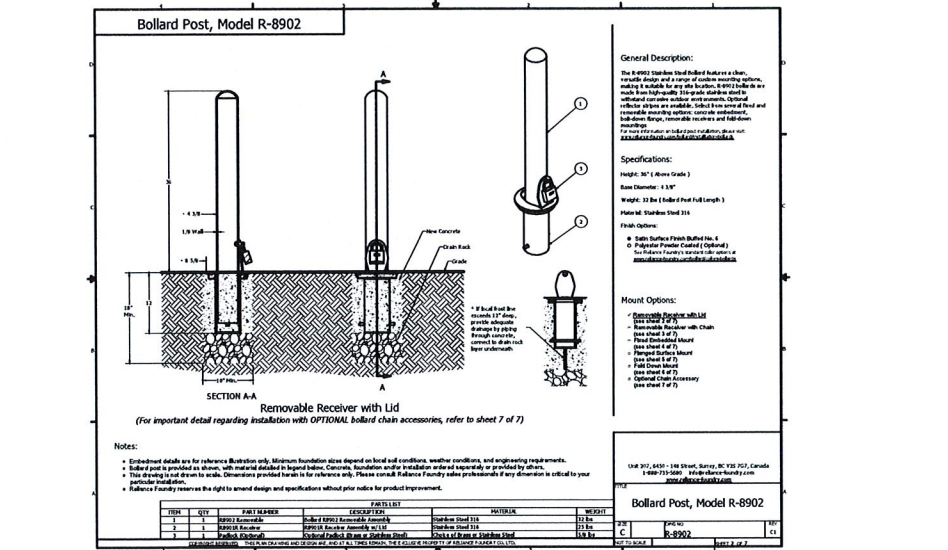
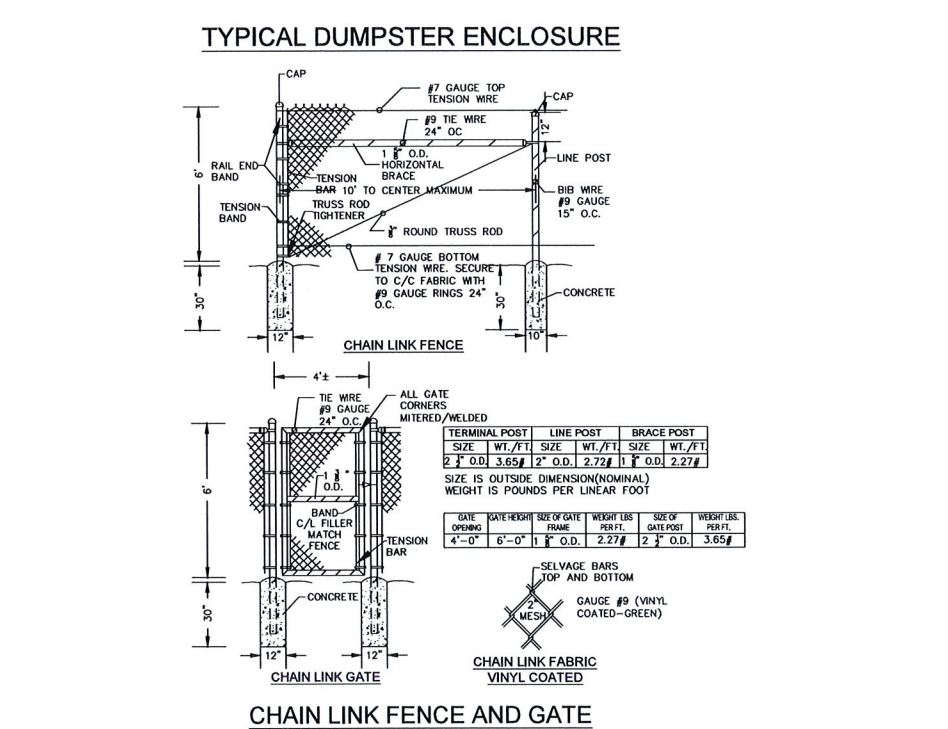
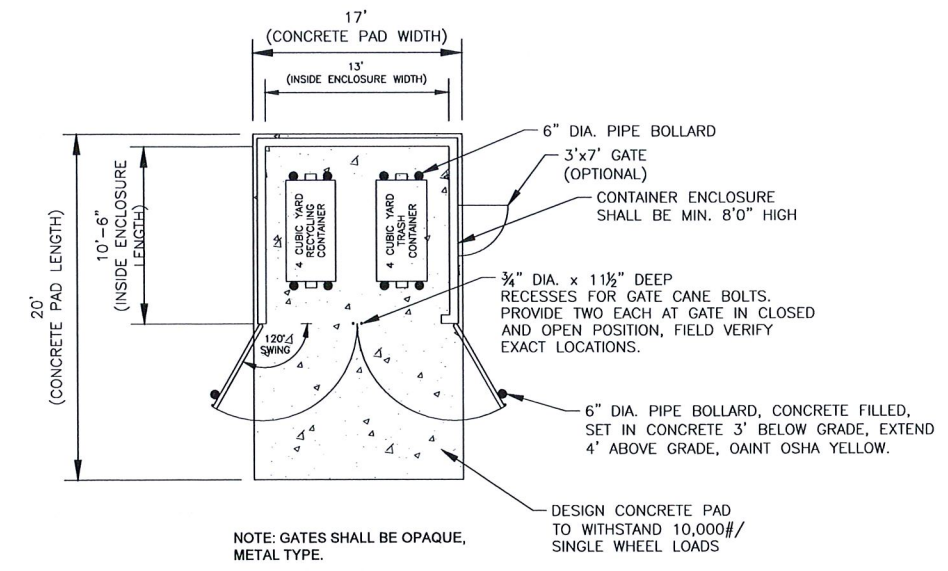
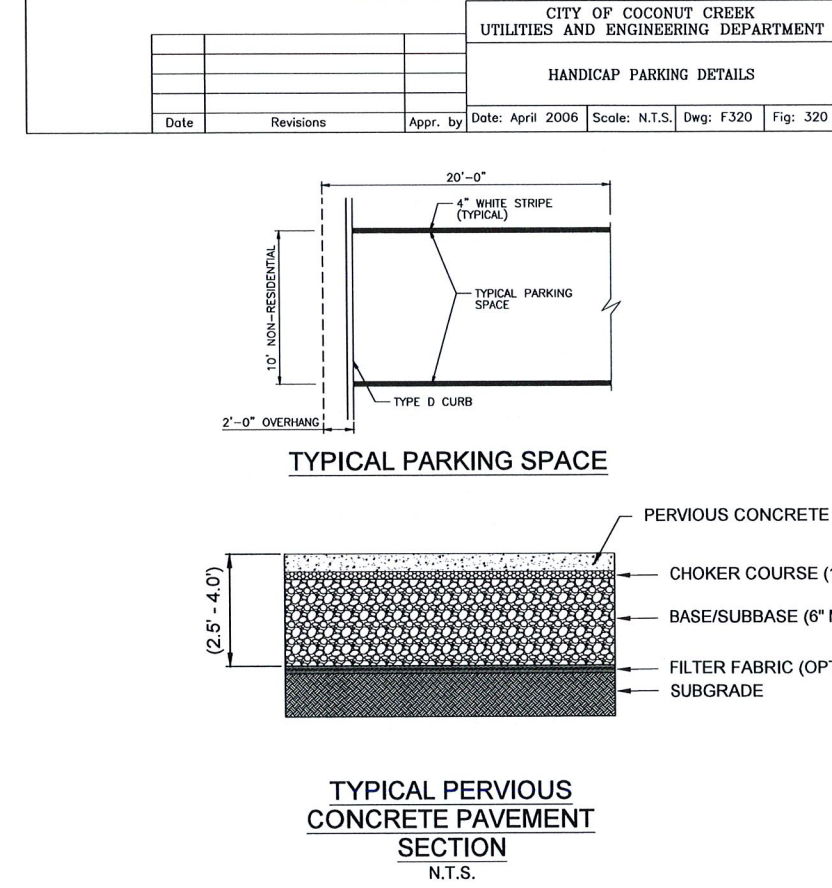
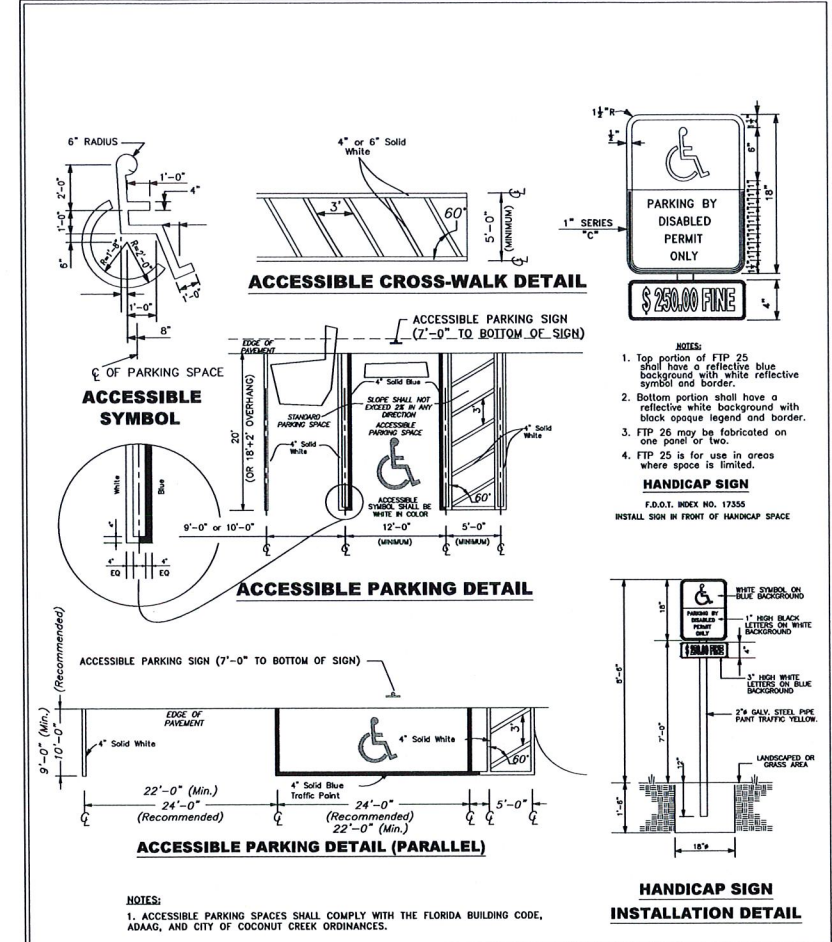
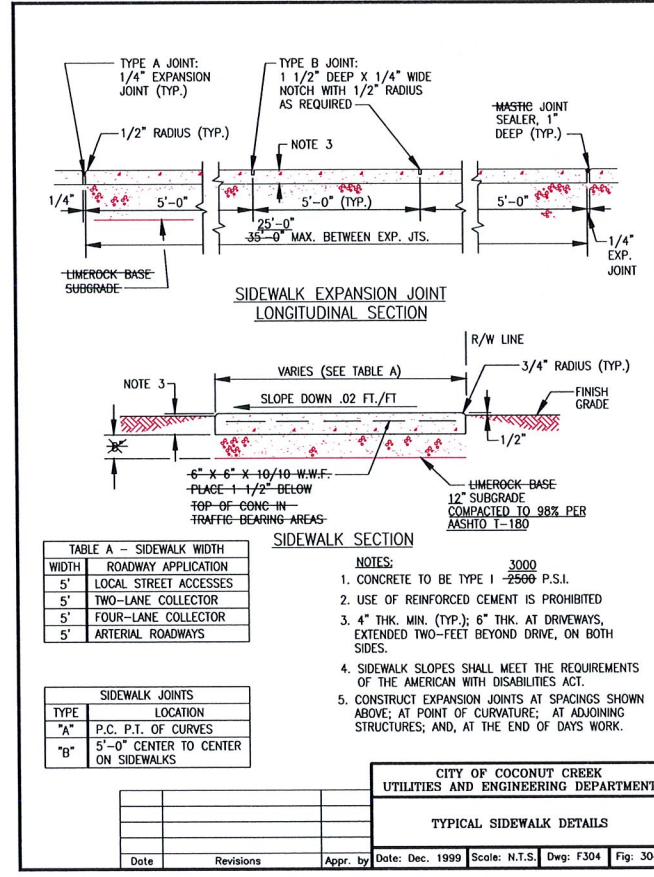
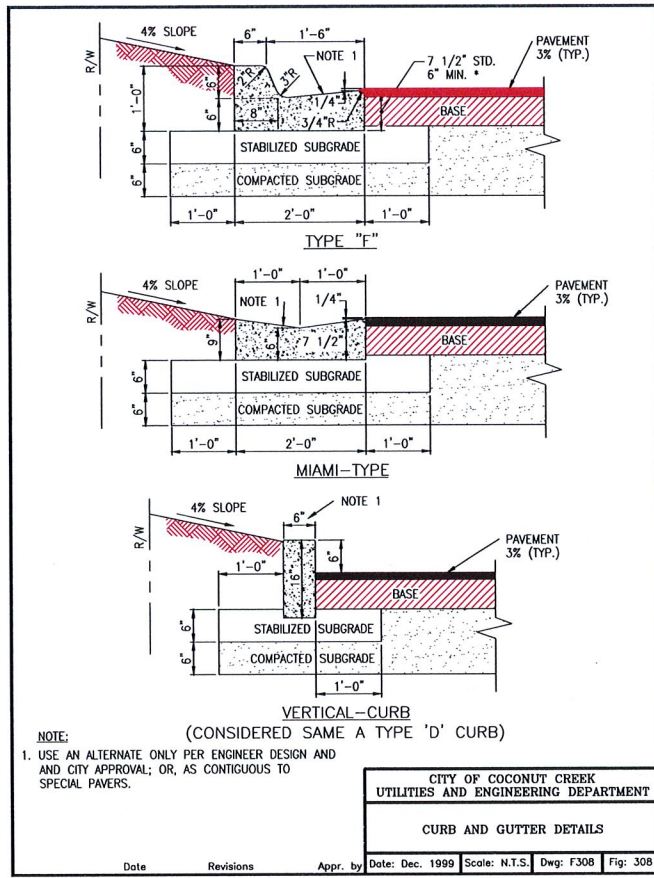

IBI GROUP (FLORIDA) INC
1100 Park Central Boulevard South - Suite 3500
Pompano Beach FL 33064 USA
tel 954 974 2200 fax 954 973 2686
ibigroup.com

LYONS COMMUNITY CENTER
7660 LYONS, COCONUT CREEK, FL.

SITE PLAN DETAILS

Patricia F. Ramundo
Digitally signed by Patricia F. Ramundo
Date: 2019.01.31 13:26:41 -05'00'
Date: 3/7/2018

DRAWN: CMP
SCALE: N.T.S.
DESIGNED: CMP
PROJECT: 109511
CHECKED: PFR
SHEET: C3.2
DATE: 3/7/2018