



November 8, 2019

Liz Aguiar
Principal Planner
City of Coconut Creek
4800 W. Copans Road
Coconut Creek, Florida 33063

**RE: 7-Eleven at Coconut Creek Parkway and Banks Road DRC Justification
7-Eleven Project #34941 / KEITH Project Number 09725.64**

On behalf of 7-Eleven, Inc. ("Applicant"), we are pleased to submit requests for **rezoning, site plan, and special land use** approval to redevelop two properties located at the southeast corner of Coconut Creek Parkway (C.R. 912) and Banks Road in the City of Coconut Creek with the following addresses: 4990 and 4960 Coconut Creek Parkway (the "Subject Property") totaling 1.32 acres. The proposed redevelopment includes the demolition of all structures on the Subject Property and the construction of a new 7-Eleven convenience store with 16 fueling positions. The proposed 7-Eleven will replace an existing gas station, convenience store and commercial tool rental establishment. The following narratives provide specific information about each property:

4990 Coconut Creek Parkway (Folio No. 484231010055) – "Corner Parcel"

This parcel is owned by 7-Eleven and is currently developed with a 960 square foot convenience store, a gas station with six (6) multiple product dispensers (MPDs), 12 fueling positions, and a 648 square foot automatic carwash. The existing development was built in 1991 and was constructed with an older, now-outdated style of development. The design includes a small, architecturally sparse convenience store constructed underneath the fueling canopy. The site is approximately 0.62 acres.

4960 Coconut Creek Parkway (Folio No. 484231010054) – "East Parcel"

This parcel is owned by Thomas Kiel and is currently developed with a 2,845 square foot commercial structure that is currently used for tool rentals. The property was developed in 1983. The site is approximately 0.70 acres.

When combined, the two parcels total approximately 1.32 acres.

Ownership

The Corner Parcel at 4990 Coconut Creek Parkway (Folio No. 484231010055) is currently owned by 7-Eleven. The East parcel located at 4960 Coconut Creek Parkway (Folio No. 484231010054) is currently owned by Thomas Kiel. Thomas Kiel and 7-Eleven executed a purchase agreement on December 18, 2018 for 7-Eleven to purchase parcel 484231010054.

Combination of Parcels

The Applicant proposes to combine the Corner Parcel and the East Parcel with a Unity of Title. The combination of the two properties allows for the redevelopment of the combined site. The combined site allows for the improvement

Corporate Office
301 E Atlantic Blvd
Pompano Beach
FL 33060
954.788.3400

Miami-Dade County
2160 NW 82 Ave
Doral
FL 33122
305.667.5474

Broward County
2312 S Andrews Ave
Fort Lauderdale
FL 33316
954.788.3400

Palm Beach County
120 N Federal Hwy
Suite 208
Lake Worth, FL 33460
561.469.0992

Orange County
321 N Crystal Lake Drive
Suite 208
Orlando, FL 32803
954.788.3400

of the access driveways including the decreased number of curb cuts along Coconut Creek Parkway. The combined site also allows the Applicant to provide more open space than the City's code requires, and more than the amount provided on the existing sites.

Site Demolition

The Applicant proposes the demolition of all existing structures on the property, including the existing convenience store, gas canopy and associated pumps and structures, drive-thru carwash, and tool rental building. The proposed demolition includes closing two of three access points along Coconut Creek Parkway.

Proposed Development

The site plan proposes a new 3,500 square foot convenience store and a gas station with eight (8) MPDs and 16 fueling positions. The Applicant will not replace the existing automatic car wash. The proposed development includes 28 off-site parking spaces, a loading zone, and a dumpster enclosure with garbage and recycling receptacles.

Architecture

The proposed building improves upon the existing, dated buildings on the site. The new convenience store building will include exterior materials consisting of a two-tone masonry stucco finish. The building footprint is designed with a series of bump-outs that provide vertical elements to break up the façade and add depth. A water table at 3'-4" provides a natural transition point for the change in building materials on the façade and it provides horizontal relief to increase interest and aesthetic appeal. A stone base provides mass and additional material, to complement the stucco finish. All four sides are treated with similar elements to provide a harmonious design; however, the entry feature includes decorative brackets and enhanced stone pilasters that differentiate it from the rest of the building while maintaining a cohesive vernacular.

The project includes sustainable components such as a "green screen" that allows nature to interact with the building while providing a shading effect that dissipates direct sunlight and reduces building heat. In addition, the building includes canopy awnings at the entrance and front of the structure to shade the windows, which results in a reduction of the overall heat load in the building. This reduction in heat allows the building to use a smaller HVAC system, resulting in a reduction in electricity use and an increase in overall building efficiency. The project architect, Ryan Faust, is LEED certified.

Buffering, Landscaping and Green Areas

The site plan includes significant multi-layered perimeter buffers as required by the City's Land Development Code. A 20-foot Right-of-Way ("ROW") buffer is provided along both Coconut Creek Parkway and Banks Road. The site plan also provides landscape buffers along property boundaries that meet or exceed City code requirements.

Landscaping is comprised of native and non-native trees, shrubs, and groundcovers that all attract wildlife in varying degrees. The tree layer incorporates existing trees and palms of varying sizes and includes a mix of native canopy trees with flowering and accent trees throughout the site. The multi-layered buffers are comprised of screening hedges with beds of grasses and flowering shrubs that taper down to a mix of groundcover. All the plants have been selected to beautify the property, provide screening, reduce maintenance and watering needs, and to invite birds and pollinators.

Vehicle Access

Drivers can access the site from either Coconut Creek Parkway or Banks Road. The proposed site plan reduces the number of curb cuts on Coconut Creek Parkway from three (3) to one (1). The proposed site plan also lengthens the driveway that provides access to Coconut Creek Parkway. The site plan and access points were reviewed by Broward County Highway Construction and Engineering Division.



Bicycle and Pedestrian Access

Pedestrians and bicyclists can access the property via an onsite sidewalk that connects the convenience store to the sidewalk along Coconut Creek Parkway and the broader pedestrian and bicycle network. The site plan includes easily accessible bicycle racks for patrons that arrive by bicycle.

Utility Undergrounding

FPL has reviewed the proposed site plan and determined that the overhead wires adjacent to the 7-Eleven shall not be converted to underground at the time of construction since it would create additional points of failures for the FPL facilities. Instead, FPL recommended that the site undergrounding of the overhead wires shall be completed along with the planned overall undergrounding of Coconut Creek Parkway. FPL has determined that the cost of undergrounding the overhead wires will be approximately \$67,550.00. The letter from FPL has been provided with this submittal.

Site Plan Request

The Applicant is requesting site plan approval for the subject property. The following list from Code Section 13-37(b) requests information about how the project addresses the City's Design Criteria. Applicant responses are provided below each criterion.

- (1) Harmonious and efficient organizations. The site plan shall be organized harmoniously and efficiently in relation to topography, the size and type of plot, the character of adjoining property, and the type and size of buildings. The site will be developed to facilitate orderly development of surrounding property.

Response: The site plan and development program are organized to improve the character of the site by improving the site's layout, developing a modern convenience store building and fuel canopy, improving vehicle and pedestrian access, and enhancing the site's landscape palate. The improved landscaping includes vegetation that supports wildlife, including butterfly ecology. The proposed structures are compatible with surrounding buildings and implement the City's aesthetic vision. Out of the 57,398 square feet that comprise the site, only 3,505 square feet are being utilized for the convenience store and 4,248 square feet are used for the canopy making it a compact and efficient site.

- (2) Preservation of natural state. Desirable vegetation or other unique natural features shall be preserved in their natural state when practical. Tree and soil removal and filling of natural watercourses shall be minimized.

Response: The Applicant, in determining the location for the site, located the buildings, structures, and driveways in locations that could preserve existing vegetation while allowing space for the proposed improvements. The Applicant aims to preserve as much of the existing vegetation as possible along the north and south property lines. The proposed development plan does include the removal of vegetation along the boundary of the two parcels that comprise the subject property. The Applicant plans to mitigate the vegetation removal with additional planting and by increasing pervious areas on the property that are currently covered by asphalt. The Applicant is proposing a dedicated landscaped parcel along adjacent roadways as required by the City's Land Development Code.

- (3) Enhancement of residential privacy. The site plan shall provide reasonable visual and sound privacy for all adjacent dwelling units. Fences, walks, barriers and vegetation shall be arranged for protection and privacy.

Response: The site is not adjacent to any residential development. However, the Applicant plans to vegetate the property appropriately, enhancing the natural aesthetics of the area and improving the visual impact from adjacent commercial developments.



- (4) Emergency access. Structures and other site features shall be arranged to permit practical emergency vehicle access to all sides of buildings.

Response: The proposed layout includes ingress and egress points on both Coconut Creek Parkway and Banks Road. These access points provide emergency accessibility from different roadways and allows emergency vehicles to freely access the site. All structures on the site are accessible from internal driveways.

- (5) Access to public ways. Every structure and dwelling unit shall have access to a public street, walkway or other area dedicated to common use.

Response: The proposed convenience store provides vehicle and pedestrian access to Coconut Creek Parkway. The site provides vehicle access to Banks Road. Pedestrians can access Banks Road via the public sidewalk network.

- (6) Pedestrian circulation. A pedestrian circulation system shall be provided which is separate from the vehicular circulation system.

Response: The site plan provides a pedestrian circulation system which includes a sidewalk separated from the driveways for safe and convenient access. The sidewalk provides access to the convenience store and a connection to the broader pedestrian network.

- (7) Design of access and egress drives. The location, size, and numbers of ingress and egress drives to a site will be designed to minimize the negative impacts on public and private streets and on adjacent property.

Response: The proposed site plan maintains the existing number of access points along Banks Road but reduces the number of access points along Coconut Creek Parkway from three to one. A Trip Generation Analysis prepared by KEITH's Traffic Engineer supporting these changes was provided to the City on September 20, 2019.

- (8) Coordination with off-site vehicular and pedestrian circulation systems. The arrangement of rights-of-way or easements for vehicular and pedestrian circulation shall coordinate the pattern of existing and planned streets and pedestrian or bicycle pathways in the area.

Response: In the Trip Generation Analysis, the Engineer recommends that a new turn lane be added along Coconut Creek Parkway and the proposed site plan reflects the proposed dedication for the turn lane. A separate entity is presently processing a plat application which includes the turn lane dedication. The proposed plat will be consistent with Broward County standards.

- (9) Stormwater control. Protective measures shall ensure that removal of stormwater runoff will not adversely affect neighboring properties or the public storm drainage system. Provisions shall be made for construction of wastewater facilities including grading, gutters, piping to direct stormwater and prevent erosion. Surface water on all paved areas shall be collected at intervals which do not obstruct vehicular or pedestrian traffic.

Response: Pre-development vs. post-development calculations shall be prepared to show that the proposed drainage system will not adversely impact adjacent properties or rights-of-way. Stormwater pre-treatment and stormwater quality treatment shall be provided on-site by way of dry retention areas and exfiltration trenches. The proposed drainage system shall consist of drainage structures located at low points in the drive aisles. Site grading will direct stormwater to the drainage structures which will in turn convey the stormwater into exfiltration trench and dry retention areas for percolation into the ground.

- (10) Exterior lighting. Location, type, size and direction of exterior lighting shall not glare or direct illumination which interferes with adjacent properties or safety of public rights-of-way.



Response: The proposed fixtures are located on the building, on poles throughout the site, and under the fuel canopy. These fixtures are shielded to comply with the City's lighting requirements including the reduction of glare, to preserve ROW safety, and to minimize interference with adjacent properties. The proposed exterior lighting approach is illustrated on the photometric plan provided as part of the application package.

- (11) Protection of property values. Elements of a site plan shall be arranged to have minimum negative impact on values of adjoining property.

Response: The proposed redevelopment project is anticipated to increase the value of the property by replacing outdated, existing structures with modern structures that advance the City's aesthetic vision.

Rezoning Map Amendment Request

The Applicant is requesting a rezoning of one of the parcels that comprise the subject property. Both subject properties are designated Commercial (C) on the City of Coconut Creek's Comprehensive Plan Future Land Use Map. However, the properties have different zoning designations: the Corner Parcel is designated Convenience Shopping District (B-2) and the East Parcel is designated Community Shopping District (B-3).

Future Land Use Analysis

The underlying Commercial (C) future land use designation supports commercial land use and therefore commercial zoning districts. Therefore, the Commercial (C) future land use designation is consistent with the proposed B-3 zoning request.

Rezoning Request

The Applicant requests to rezone the corner parcel to bring the entire site under a consistent zoning district, and thus, a consistent set of development rules. The Applicant proposes to rezone the Corner Parcel from B-2 to B-3, based on the criteria outlined in the City's Land Development Code and discussion during the pre-application conference with City Staff. This parcel is surrounded by a large area that is currently zoned B-3; therefore, rezoning this property will make the site's zoning consistent with the adjacent property and broader area. The B-3 zoning district allows Convenience Store with Fuel Sales as a Special Land Use.

Pursuant to Code Section 13-36(e), the City shall make a determination based on evidence related to the following items. The Applicant has provided responses to each item below.

- (1) Is not contrary to the comprehensive plan;

Response: The proposed B-3 district is consistent with the underlying Commercial (C) Future Land Use Map designation. The proposed rezoning is also consistent with the City's Comprehensive Plan including, but not limited to, the following Objectives and Policies from the Future Land Use Element:

Objective II-2.1.0 Accommodate office, retail and other activities needed for the provision of goods and services to permanent and seasonal populations. (B.C.P.C. 2.01.00)

- *The proposed special land use includes retail and provides goods and services to the community.*

Policy II-2.1.5 Include in the Land Development Code separate zoning categories for neighborhood, community and regional commercial development which set forth intent, location criteria and development standards consistent with the following policies:

- b. Community commercial uses are those which serve the needs of several neighborhoods and are most appropriately located on major thoroughfares with adequate buffering from residential



development.

- *The proposed project zoning is community shopping district (B-3) and the proposed special land use provides commercial services to the community. Additionally, the site is located on an arterial roadway and a collector roadway pursuant to the Broward County Trafficways plan. The site is not located adjacent to residential and is appropriately buffered with vegetation along street frontages and property lines.*

Policy II-2.5.2 Continue to ensure through the Land Development Code that all future commercial uses are subject to site plan review standards which mitigate adverse impacts on adjacent land uses. (B.C.P.C. 2.04.09, 2.04.02)

- *The proposed development is consistent with the City's Land Development Regulations.*

(2) Will not create an isolated zoning district which would be unrelated and incompatible with adjacent districts;

Response: The proposed B-3 zoning district is the same as and thus compatible with the adjacent B-3 zoning district.

(3) Will not substantially impact public facilities such as schools, utilities and streets;

Response: The proposed rezoning to B-3 is intended to facilitate the development of a convenience store with fuel sales. The proposed use will not have a negative impact on utilities or streets. Further, the proposed redevelopment will not include a residential component and thus will not impact schools.

(4) Will be justified by external land use conditions;

Response: The conditions of the land do not prohibit or affect the proposed redevelopment. The proposed redevelopment will replace an existing convenience store with fuel sales with the same use and an existing commercial building currently being used for tool rentals.

(5) Will not create or excessively increase automobile and vehicular traffic congestion;

Response: Consistent with the trip generation analysis submitted to the City by KEITH, the Applicant is providing a new turn lane to improve the flow of traffic at the intersection of Coconut Creek Parkway and Banks Road.

(6) Will not create a storm drainage problem for other properties;

Response: Pre-development vs. post-development calculations shall be prepared to show that the proposed drainage system will not adversely impact adjacent properties or rights-of-way. Stormwater pre-treatment and stormwater quality treatment shall be provided on-site by way of dry retention areas and exfiltration trenches. The proposed drainage system shall consist of drainage structures located at low points in the drive aisles. Site grading will direct stormwater to the drainage structures which will in turn convey the stormwater into exfiltration trench and dry retention areas for percolation into the ground.

(7) Will not adversely affect surrounding living conditions;

Response: The subject property is not located adjacent to residentially zoned property and, therefore, will not directly impact residential development. The proposed redevelopment will create new structures that improve the aesthetics of the property and adds landscaping enhancements that improve the natural environment. The site reduces curb cuts along Coconut Creek Parkway. The resulting new development improves living conditions for the City as a whole.

(8) Will not seriously affect environmental quality;



Response: Both the existing B-2 zoning district and the proposed B-3 zoning district require a minimum of 15 percent open space; therefore, the change in zoning will not result in a reduction of the required open space on the property. The proposed site plan increases the amount of open space beyond the amount that currently exists on the property. Specifically, the site plan includes 46 percent open space, which is greater than the 15 percent open space required by both the B-2 and B-3 zoning districts. The proposed project removes an existing convenience store with fuel sales establishment, an automatic car wash, and an existing commercial structure and replaces these uses with a convenience store and gas station. Therefore, the intensity of the number of uses is being reduced. The landscape plan includes enhanced buffers and new vegetation, which increases environmental quality. The proposed redevelopment will include the removal of existing fuel tanks and the replacement with new fuel tanks that utilized improved technology that improves environmental quality versus the previous condition. The proposed rezoning is not anticipated to affect environmental quality.

- (9) Will not adversely affect other property values;

Response: The proposed rezoning and redevelopment will allow the improvement of the property and is expected to increase the property value. The proposed redevelopment will be the same use as the existing property. No adverse effects on property values are anticipated. The subject property is not located adjacent to residentially zoned property and, therefore, will not impact residential development.

- (10) Will not be a deterrent to improvement or development of other property;

Response: The proposed project is self-contained and will have no impact on development decisions on nearby properties. The proposed rezoning is consistent with the larger, contiguous B-3 district. This project will improve an important corner in the City and will be a catalyst for additional, new development in the area.

- (11) Will not constitute a special privilege to an individual owner.

Response: The proposed rezoning makes the parcel consistent with the larger, contiguous B-3 zoning district. The proposed rezoning will not result in spot zoning, as the B-3 district is already adjacent to the parcel proposed to be rezoned. The proposed project intends to redevelop the property's existing use. Therefore, rezoning will not confer a special privilege to the owner.

Special Land Use Request

Pursuant to the City of Coconut Creek's Land Development Code Section 13-621 and 13-371(11)(d), the Applicant is requesting Special Land Use approval for the Convenience Store with Fuel Sales Use and Motor Fuel Sales. Pursuant to Code Section 13-35(f), the City shall make a determination based on evidence related to the following items. The Applicant has provided responses to each item below.

- (1) The proposed special land use will be in harmony with nearby uses permitted under Article III of this chapter;

Response: The convenience store with fuel sales use is appropriate at this location because it is located at the intersection of two roads: an arterial roadway and a collector roadway pursuant to the Broward County Trafficways Plan. The property is not adjacent to residential development but provides residents of the area a convenient location for vehicle refueling and purchasing convenience items. The same convenience store with fuel sales special land use currently exists on the property and is currently in harmony with nearby uses.

- (2) The proposed special land use will be in harmony with nearby existing uses;

Response: The existing use, which is also classified as a special land use, is in harmony with nearby existing uses. The proposed use and development program improve on the existing development and will



also be in harmony with nearby existing uses.

- (3) The proposed special land use must be reasonably compatible with surrounding and adjacent uses in its function, its hours of operation, the type and amount of traffic to be generated, the building size and setbacks, and its relationships to the land values;

Response: The proposed special land use is compatible with the surrounding adjacent uses. Its function, to provide a convenience service to residents and travelers, is consistent with nearby auto oriented uses and other surrounding uses. The development is proposed to operate 24-hours. The site is not adjacent to residential development and the 24-hour operation will not impact residential development. The proposed building size is proportionate to the site and the buildings meet or exceed the City's setback requirements for the B-3 zoning district. The proposed development is anticipated to increase the value of the property by demolishing the older, existing structures and replacing them with modern, aesthetically appealing structures that are consistent with the City's vision.

- (4) The proposed special land use will be in the best interests of the city, the convenience of the community, the public welfare, and be a substantial improvement to the property in the immediate vicinity;

Response: The proposed convenience store is ideally suited to provide an enhanced level of convenience for the community. The site's updated design will be in the best interest of the surrounding properties, communities, and the City. The proposed redevelopment includes replacing existing fuel tanks and pumps, creating a state-of-the art facility with clean technology, which is in the best interests of the City, community and public welfare.

- (5) The proposed special land use will contribute to the economic stability of the community;

Response: The proposed special land use is a commercial use that will provide a service, create jobs, and generate tax revenues, which will enhance the economic stability of the community.

- (6) The proposed special land use will not decrease public benefit or increase undesirable impacts other than those resulting from use of the site as permitted by right under Article III of this chapter or some other special land use permitted on the site;

Response: The proposed special land use replaces and effectively continues a commercial business with the same convenience store and fuel sales services. The new structures that utilize the City's aesthetic vision will increase the public benefit.

- (7) The proposed special land use will not result in more intensive development than what is approved by the land use element of the comprehensive plan.

Response: The proposed use is consistent with the intensity standards of the land development code and comprehensive plan. The Comprehensive Plan allows a maximum of 1.5 FAR. The B-3 zoning district limits sites to 0.5 FAR. The redevelopment project proposes 0.06 FAR.

- (8) The proposed special land use will be consistent with goals, objectives, and policies of the comprehensive plan.

Response: The proposed special land use is consistent with the goals, objectives and policies of the comprehensive plan including, but not limited to, the following objectives and policies in the Future Land Use Element.

Objective II-2.1.0 Accommodate office, retail and other activities needed for the provision of goods and services to permanent and seasonal populations. (B.C.P.C. 2.01.00)



- *The proposed special land use provides goods and services to the community.*

Policy II-2.1.5 Include in the Land Development Code separate zoning categories for neighborhood, community and regional commercial development which set forth intent, location criteria and development standards consistent with the following policies:

b. Community commercial uses are those which serve the needs of several neighborhoods and are most appropriately located on major thoroughfares with adequate buffering from residential development.

- *The proposed project zoning is community shopping district (B-3) and the proposed special land use provides commercial services to the community. Additionally, the site is located on an arterial roadway and a collector roadway pursuant to the Broward County Trafficways plan. The site is not located adjacent to residential, but it is appropriately buffered with vegetation along street frontages and property lines.*

Policy II-2.5.2 Continue to ensure through the Land Development Code that all future commercial uses are subject to site plan review standards which mitigate adverse impacts on adjacent land uses. (B.C.P.C. 2.04.09, 2.04.02)

- *The proposed development is consistent with the City's Land Development Regulations.*

Additionally, pursuant to Code Section 13-35(g), the City shall make a determination based on evidence related to the following items. The Applicant has provided responses to each item below.

- (1) The proposed use will not reduce the level of service provided on any street to a lower level than would result from a development permitted by right.

Response: The proposed use will improve the flow of traffic on Coconut Creek Parkway with the addition of a turn lane and by reducing the number of curb cuts from three to one. Furthermore, the proposed use is very similar to the existing use on the subject property and is not expected to reduce the level of service provided on any street to a lower level than would a development permitted by right.

- (2) The proposed use will not result in a significantly greater amount of through traffic on local streets than would result from a development permitted by right.

Response: The proposed development replaces an existing fuel tank station and accessory uses with a new one. The amount of traffic generated by this request would not be significantly greater than what is generated by the current site

- (3) The proposed use will not require extension or enlargement of the thoroughfare system at a higher net public cost than would result from a development permitted by right.

Response: Thoroughfare improvements that are necessitated by this development will be paid for by the applicant at no cost to the public.

- (4) The proposed use will not require enlargement or alteration of utility facilities, drainage systems, and other utility systems other than what would result from a development permitted by right.

Response: Pre-development vs. post-development calculations shall be prepared to show that the proposed drainage system will not adversely impact adjacent properties or rights-of-way. Stormwater pre-treatment and stormwater quality treatment shall be provided on-site by way of dry retention areas and exfiltration trenches. The proposed drainage system shall consist of drainage structures located at low points in the drive aisles. Site grading will direct stormwater to the drainage structures which will in turn convey the stormwater into exfiltration trench and dry retention areas for percolation into the ground. The



site has been graded so that it slopes from west to east, directing stormwater away from the proposed parking spaces.

- (5) The proposed use will not demand greater municipal public safety services exceeding the demand resulting from a development permitted by right.

Response: The proposed use will not demand greater municipal public safety service exceeding those resulting from a development permitted by right. The proposed development decreases the level of development that currently exists on the site by 2,112 square feet (5,617 sf total existing; 2,772 sf existing convenience store & 2,845 sf existing commercial). The proposed redevelopment will also reduce the total number of businesses operating on the property from two (2) to one (1). The Applicant anticipates that the reduction in intensity will result in a reduction of services required by the development.

- (6) If a special land use is combined with other special land uses or permitted uses on a site, the overall intensity and scale of uses on the site is appropriate given the adequacy of proposed buffers and setbacks and the land uses of surrounding properties.

Response: The scale of the proposed development is appropriate for the site. The B-3 district establishes a maximum floor area ratio of 0.5, which could allow a building with a permitted use up to 28,699 square feet. The proposed convenience store building is 3,505 square feet. The proposed development decreases the level of development that currently exists on the site by 2,112 square feet (5,617 sf total existing; 2,772 sf existing convenience store & 2,845 sf existing commercial).

On behalf of the Applicant, we look forward to working with the City.

Sincerely,



Anne-Christine Carrie

CC: Roger Posey, Creighton Development



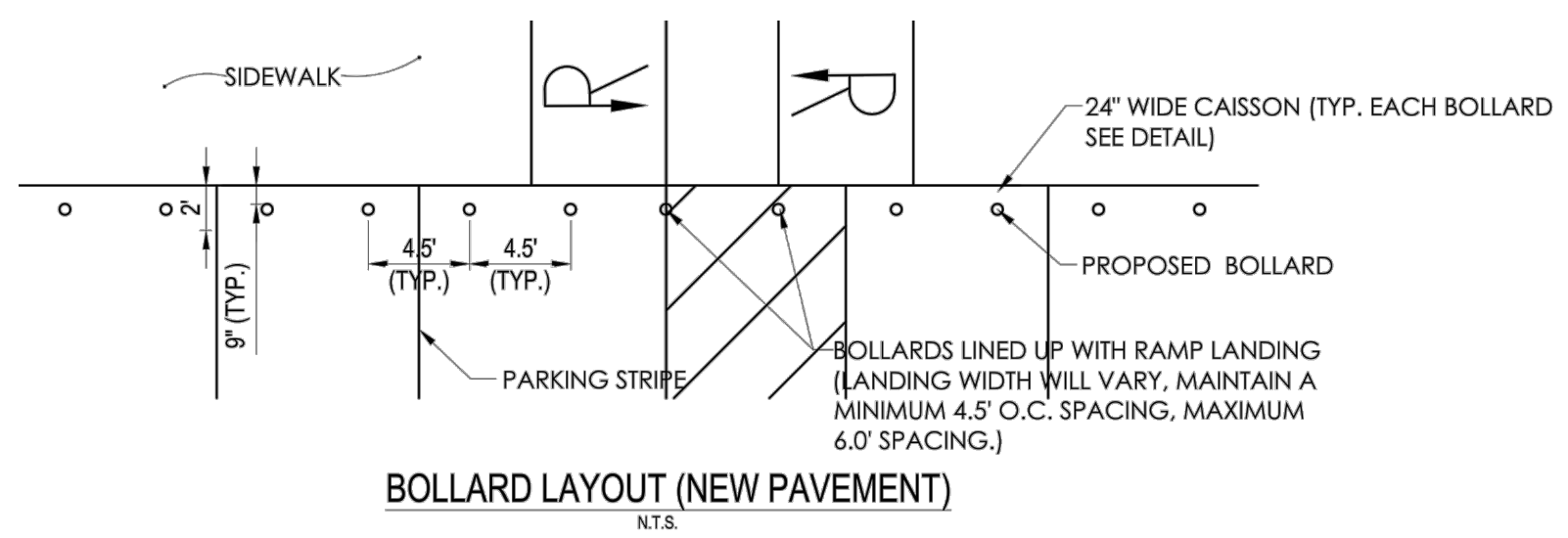

NOTE:

1. CONCRETE MUST BE A MINIMUM 4,000 PSI COMPRESSIVE STRENGTH WITH FIBER MESH.
2. PROVIDE PLASTIC BOLLARD COVER. COVER TO BE IDEALSHIELD (OR APPROVED EQUAL) 1/8" THICK, BROWN (PQ-440C), 6" PIPE FIT, DOME TOP, 48" TALL.
3. DESIGN PARAMETERS:
- 20 MPH
- 5,000 LB VEHICLE
4. USE SONOTUBE IN SANDY OR OTHER SOILS THAT MIGHT CAVE IN.
5. INCREASE DEPTH OF CAISSON BELOW PIPE TO MEET LOCAL JURISDICTION MIN. FROST DEPTH REQUIREMENT. PIPE CAN STAY AT 39" BELOW PAVEMENT.
6. IT IS THE CONTRACTOR'S RESPONSIBILITY TO VERIFY NO UTILITY CONFLICTS EXIST WHERE BOLLARDS ARE TO BE INSTALLED. PRIOR TO INSTALLATION.

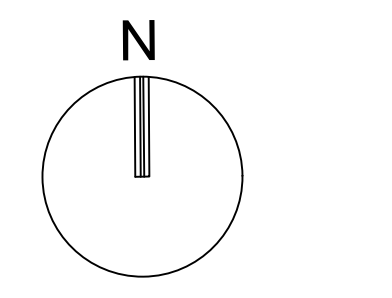
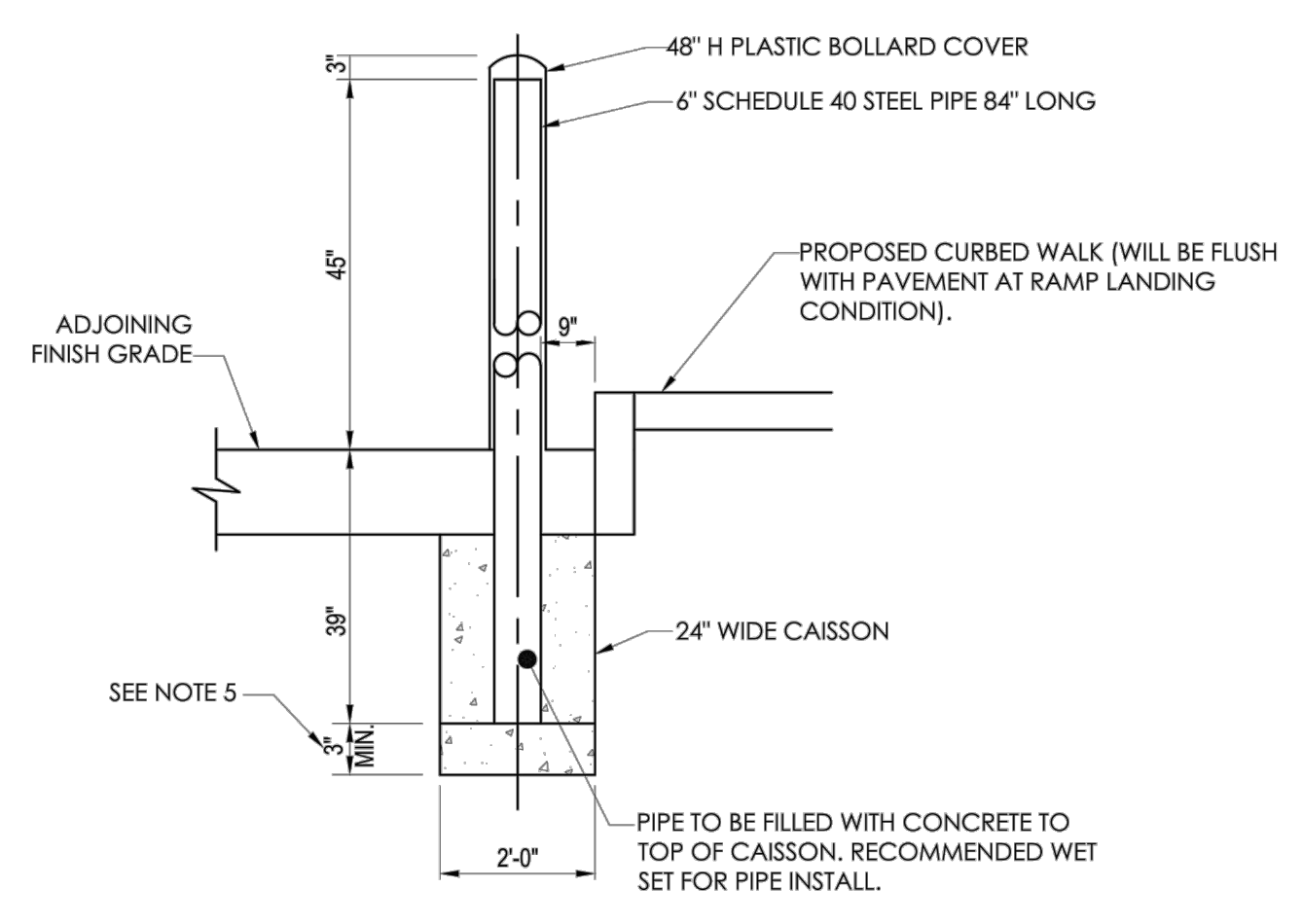

GRAPHIC SCALE
0 20 40

SCALE: 1"=20'

NOTE: PRINTED DRAWING SIZE MAY HAVE CHANGED FROM ORIGINAL. VERIFY SCALE USING BAR SCALE ABOVE.

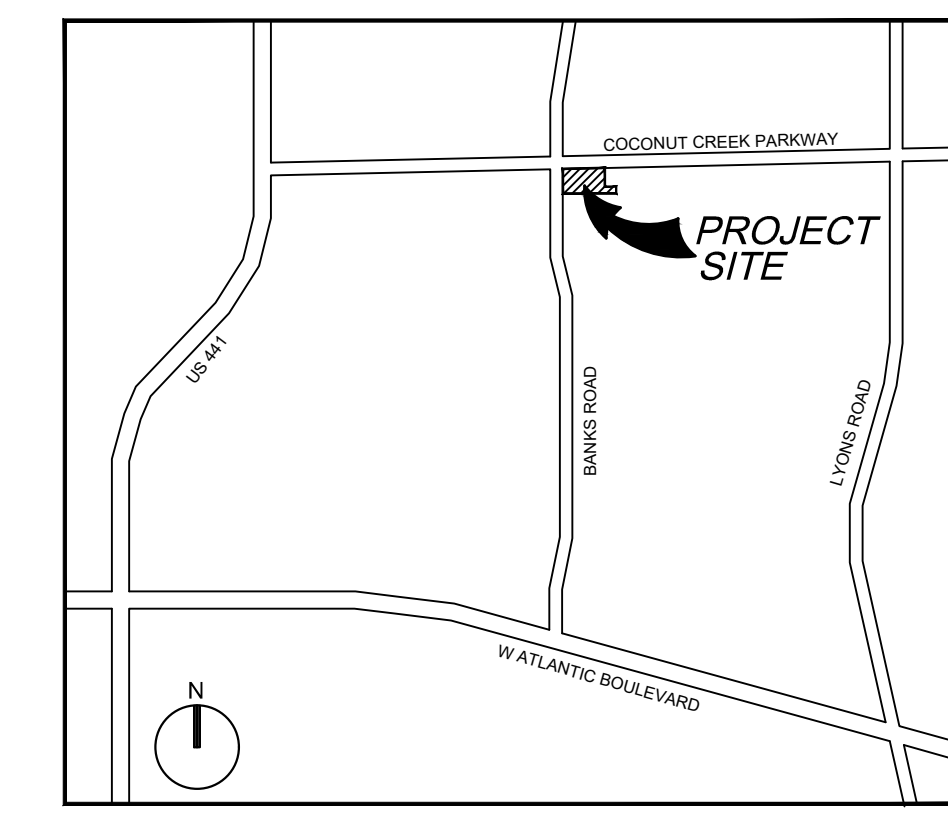

KEITH
301 East Atlantic Boulevard
Pompano Beach, Florida 33060-6643

2312 S. Andrews Ave.
Fort Lauderdale, Florida 33316

PH: (954) 788-3400

Florida Certificate of Authorization # - 7928

BID / CONTRACT NO.:

REVISIONS

NO.	DESCRIPTION	DATE

PRELIMINARY PLAN NOT FOR CONSTRUCTION
THESE PLANS ARE NOT FULLY PERMITTED AND ARE SUBJECT TO REVISIONS MADE DURING THE PERMITTING PROCESS. RESPONSIBILITY FOR THE USE OF THESE PLANS PRIOR TO OBTAINING PERMITS FROM ALL AGENCIES HAVING JURISDICTION OVER THE PROJECT WILL FALL SOLELY UPON THE USER.



7-ELEVEN #34941
4990 COCONUT CREEK PKWY.
COCONUT CREEK, FL 33063

SCALE: AS NOTED
1ST SUBMITTAL DATE: FEB. 2019

DRAWN BY:	MA
DESIGNED BY:	SL
CHECKED BY:	TD

THOMAS F. DONAHUE, P.E.
FLORIDA REG. NO. 60529
(FOR THE FIRM)

SHEET TITLE
SITE PLAN

SHEET NUMBER
SP-101

PROJECT NO. **09725.64**

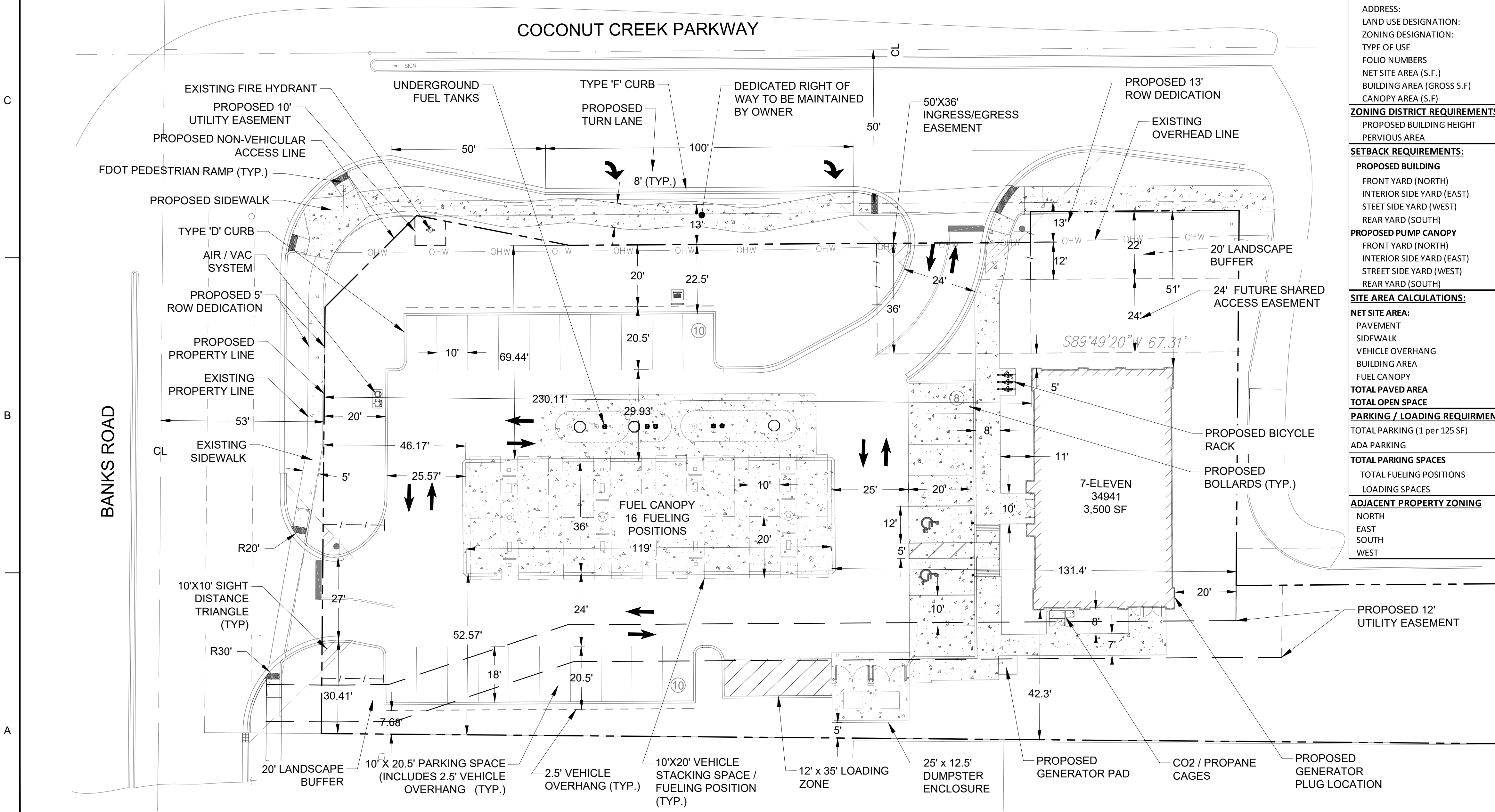

SITE DATA TABLE:

PROJECT INFORMATION:

ADDRESS: 4990 & 4960 COCONUT CREEK PARKWAY
LAND USE DESIGNATION: COMMERCIAL (C)
ZONING DESIGNATION: COMMUNITY SHOPPING (B-3)
TYPE OF USE: CONVENIENCE STORE WITH FUEL SALES
FOLIO NUMBERS: 484231010055 & 484231010054
NET SITE AREA (S.F.): 52,870 SFT 1.21 AC
BUILDING AREA (GROSS S.F.): 3,500 SFT 0.08 AC
CANOPY AREA (S.F.): 4,284 SFT 0.10 AC

ZONING DISTRICT REQUIREMENTS:

	REQUIRED	PROVIDED
PROPOSED BUILDING HEIGHT	36' MAX.	22 FT
PERVIOUS AREA	15% MIN.	43%

SETBACK REQUIREMENTS:

	REQUIRED	PROVIDED
PROPOSED BUILDING		
FRONT YARD (NORTH)	25 FT	51 FT
INTERIOR SIDE YARD (EAST)	20 FT	20 FT
STREET SIDE YARD (WEST)	25 FT	230.11 FT
REAR YARD (SOUTH)	25 FT	42.3 FT
PROPOSED PUMP CANOPY		
FRONT YARD (NORTH)	25 FT	69.44 FT
INTERIOR SIDE YARD (EAST)	20 FT	131.4 FT
STREET SIDE YARD (WEST)	25 FT	46.17 FT
REAR YARD (SOUTH)	25 FT	52.57 FT

SITE AREA CALCULATIONS:

	REQUIRED	SQ. FT.	%
NET SITE AREA:		52,870	100%
PAVEMENT		19,776	37%
SIDEWALK		2,034	4%
VEHICLE OVERHANG		366	1%
BUILDING AREA		3,500	7%
FUEL CANOPY		4,596	9%
TOTAL PAVED AREA	85%	30,272	57%
TOTAL OPEN SPACE	15%	22,598	43%

PARKING / LOADING REQUIREMENTS:

	REQUIRED	PROVIDED
TOTAL PARKING (1 per 125 SF)	28	28
ADA PARKING	2	2
TOTAL PARKING SPACES		28
TOTAL FUELING POSITIONS		16
LOADING SPACES	1	1

ADJACENT PROPERTY ZONING

NORTH	TOC-C (CITY OF MARGATE)
EAST	B-2 & B-3 (CITY OF COCONUT CREEK)
SOUTH	B-3 (CITY OF COCONUT CREEK)
WEST	TOC-C (CITY OF MARGATE)

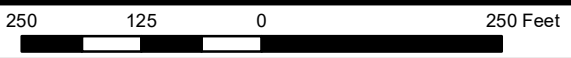
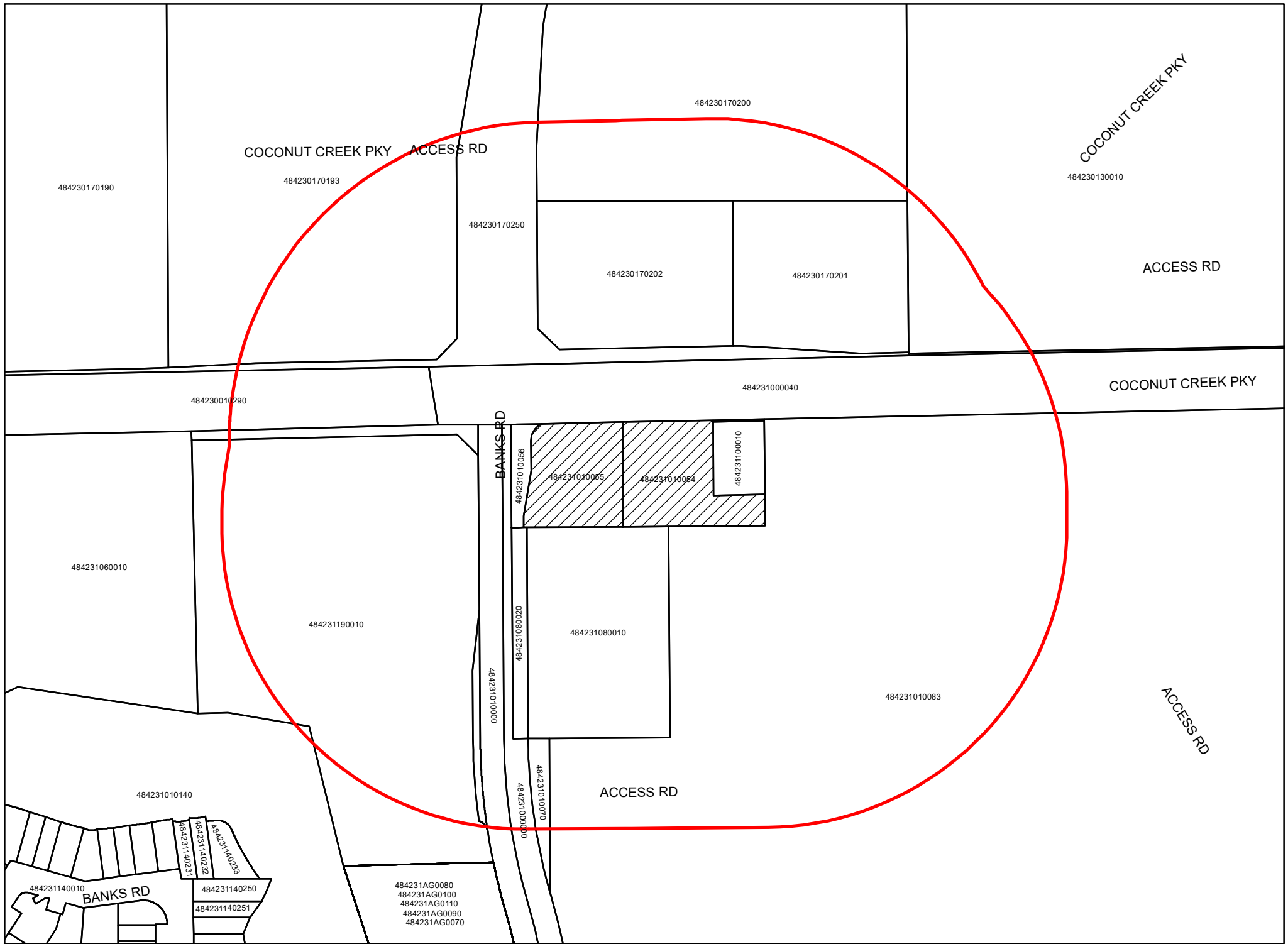

7-ELEVEN INC
1722 ROUTH ST STE 1000
DALLAS, TX 75201

CENTREPOINT PLAZA LTD PRTNR
11911 US HIGHWAY 1 STE 206
N PALM BEACH, FL 33408

CITY OF COCONUT CREEK
4800 W COPANS RD
COCONUT CREEK, FL 33063

KIEL, THOMAS
4960 COCONUT CREEK PKWY
COCONUT CREEK, FL 33063

PUBLIC LAND
CITY OF COCONUT CREEK
4800 W COPANS RD
COCONUT CREEK, FL 33063

SCHOOL BOARD OF BROWARD COUNTY
ATTN:FACILITY MANAGEMENT
600 SE 3 AVE
FORT LAUDERDALE, FL 33301

VALUE STORE IT MARGATE LLC
3201 W COMMERCIAL BLVD #218
FORT LAUDERDALE, FL 33309

BROWARD COUNTY
BOARD OF COUNTY COMMISSIONERS
115 S ANDREWS AVE RM 501-RP
FORT LAUDERDALE, FL 33301

CENTRO NP COCONUT CREEK
OWNER LLC
420 LEXINGTON AVE 7 FL
NEW YORK, NY 10170

CITY OF MARGATE
5790 MARGATE BLVD
MARGATE, FL 33063

PUBLIC LAND
CITY OF COCONUT CREEK
4800 W COPANS RD
COCONUT CREEK, FL 33063

PUBLIC LAND
CITY OF COCONUT CREEK
4800 W COPANS RD
COCONUT CREEK, FL 33063

SOUTHERN BELL TEL & TEL CO
TAX ADMIN OFF BELL SOUTH CORP
1010 PINE, 9E-L-01
ST LOUIS, MO 63101

VILLENEUVE INVESTMENTS INC
9595 COLLINS AVE APT N7-J
MIAMI, FL 33154

BROWARD COUNTY
BOARD OF COUNTY COMMISSIONERS
115 S ANDREWS AVE RM 501-RP
FORT LAUDERDALE, FL 33301

CITY OF COCONUT CREEK
4800 W COPANS RD
COCONUT CREEK, FL 33063

FLORIDA LAND TR
NAVARRETE N, MIGUEL E TRSTEE
4920 COCONUT CREEK PKWY
COCONUT CREEK, FL 33063

PUBLIC LAND
CITY OF MARGATE
5790 MARGATE BLVD
MARGATE, FL 33063

REFLECTIONS HOUSING LTD PTNR
1300 BANKS RD
MARGATE, FL 33063

TC MC MARGATE APARTMENTS LLC
3850 BIRD RD 8TH FLOOR
CORAL GABLES, FL 33146



OFFICE OF PROPERTY APPRAISER, BROWARD COUNTY FLORIDA 154001

Received From: Keith & Associates Inc

Date: 9/23/2019

**Kaitlyn Riquelmy
2312 S Andrews Ave
Fort Lauderdale, FL 33316**

Product	Item Price	Quantity	Item Total
Custom Tax Roll -- variance	\$25.00	1	\$25.00

Cashier: Heather Hanson

Total: \$25.00

Payment: Check

Anne-Christine Carrie

From: Kaitlyn Riquelmy
Sent: Friday, November 1, 2019 10:01 AM
To: Anne-Christine Carrie
Subject: FW: 09725.64 7-Eleven #34941 Coconut Creek - Community Outreach 500' Radius
Attachments: 4990 & 4960 Coconut Creek Parkway.pdf; 4990 & 4960 Coconut Creek Parkway.xlsx; OrderID=154001.pdf



Kaitlyn Riquelmy
Associate Planner
2312 S. Andrews Ave, Ft. Lauderdale
Office: 954.788.3400
Email: kRiquelmy@keithteam.com
www.KEITHteam.com

From: Heather Hanson <hhanson@bcpa.net>
Sent: Tuesday, September 24, 2019 8:04 AM
To: Kaitlyn Riquelmy <kRiquelmy@keithteam.com>
Cc: Kenny Gibbs <kgibbs@bcpa.net>
Subject: RE: 09725.64 7-Eleven #34941 Coconut Creek - Community Outreach 500' Radius

Kaitlyn,
Your files are attached along with your receipt.
Thank you,

Heather A. Hanson, CFE
GIS Analyst / InfoBroward
Office of Marty Kiar, Broward County Property Appraiser
115 S Andrews Ave Rm 111
Ft Lauderdale, FL 33301
Phone: 954-357-6855
Fax: 954-357-6980
hhanson@bcpa.net

Follow our office at <http://www.facebook.com/MartyKiarBCPA>
and <http://www.twitter.com/MartyKiarBCPA>

From: Kenny Gibbs
Sent: Wednesday, September 18, 2019 12:26 PM
To: Kaitlyn Riquelmy <kRiquelmy@keithteam.com>
Subject: RE: 09725.64 7-Eleven #34941 Coconut Creek - Community Outreach 500' Radius

7-ELEVEN COMMUNITY OUTREACH MEETING

COME JOIN US TO DISCUSS
YOUR FUTURE
7-ELEVEN!

TO BE LOCATED AT 4990 COCONUT CREEK
PARKWAY



MEETING LOCATION:

CITY OF COCONUT CREEK
COMMUNITY CENTER
MEETING ROOM C-105
1100 LYONS ROAD
COCONUT CREEK, FL 33063

MEETING DATE & TIME:

WEDNESDAY
OCTOBER 16, 2019
AT 6:00PM

